

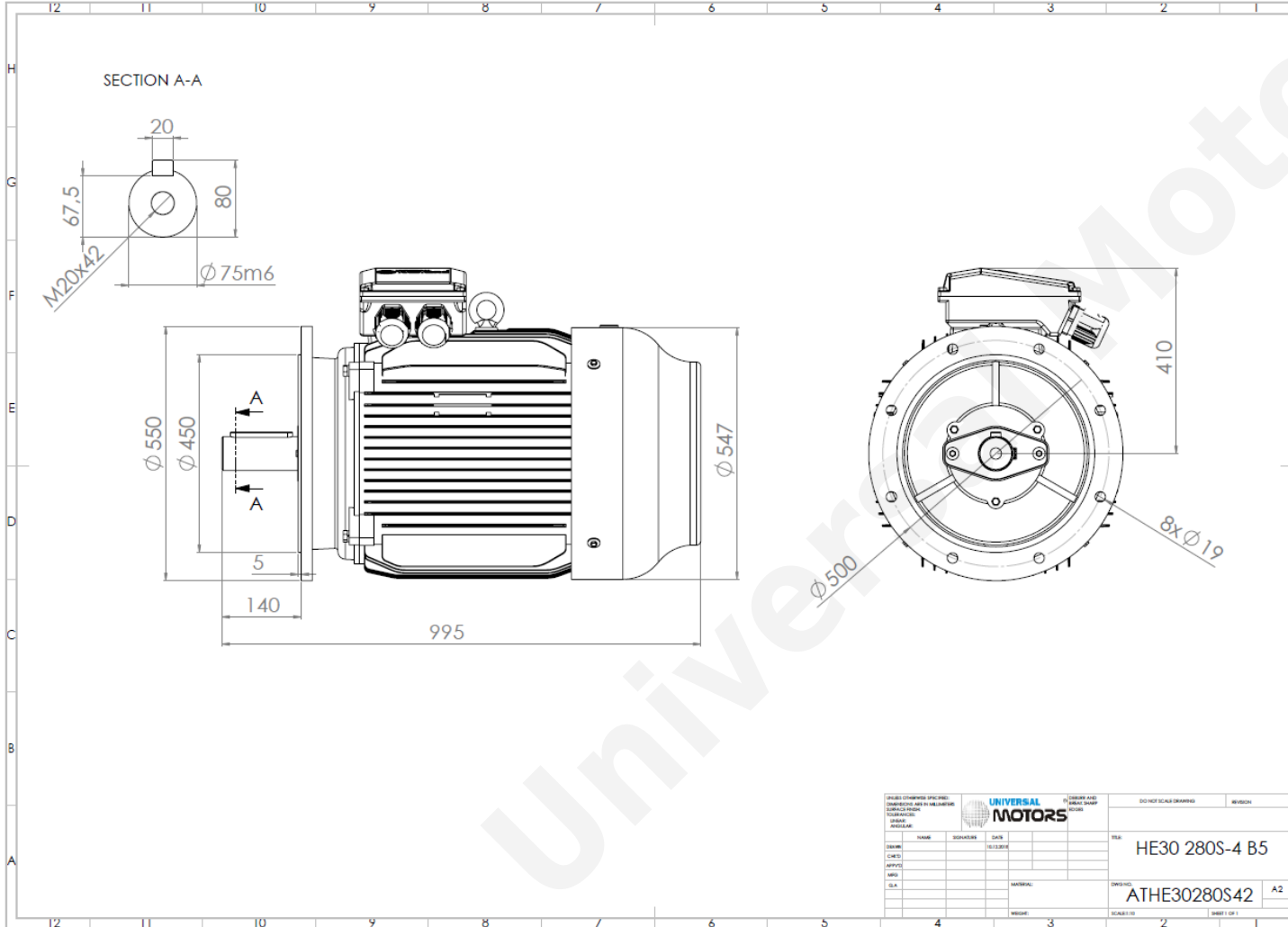

TECHNICAL DATA

Three Phase Electric Motors - Cast Iron Frame
 HE30 280 S-6 IE2
 45 kW / 60 Cv
 980 RPM



Motor type:	HE30 280 S-6 IE2
Output:	45 kW / 60 Cv
Speed (min ⁻¹):	980 RPM
Frequency:	50 Hz
Voltage:	400 V
Current:	81 A
Power factor (Cos Ø):	0.86
Poles:	6
Insulation class:	F
Temperature rise Class:	B
Efficiency 50%:	92.4 %
Efficiency 75%:	93.0 %
Efficiency 100%:	92.7 %
Torque:	439 N.m
Tstarting/Tnominal:	2.1
Istarting/Inominal:	7.2
Tmaximum/Tnominal:	2.0
Noise:	67 Db(A)
Weight:	510 Kg
Bearing DE:	6317 C3
Bearing NDE:	6317 C3

UNIVERSAL MOTORS		DO NOT SCALE DRAWING		REVISION
DESIGNER	DATE	DRW. NO.	SCALE	SHEET OF 1
HE30 280S-4 B5		ATHE30280S42	A2	

Regime - S1

Altitude - 1000m

Environment Temperature - 40°C

CONTACTS:

UNIVERSAL MOTORS Tel: +351 252 299 080
 Rua de São Brás,745 Fax: +351 252 299 089
 4480-782 VILA DO CONDE Mail: geral@universalmotors.pt

* References applied only in the UK